

Sheet: /SD Card/
 File: sdcard.kicad_sch

Title:

Size: A4
 KiCad E.D.A. 10.0.4

Date:

Rev:
 Id: 2/9

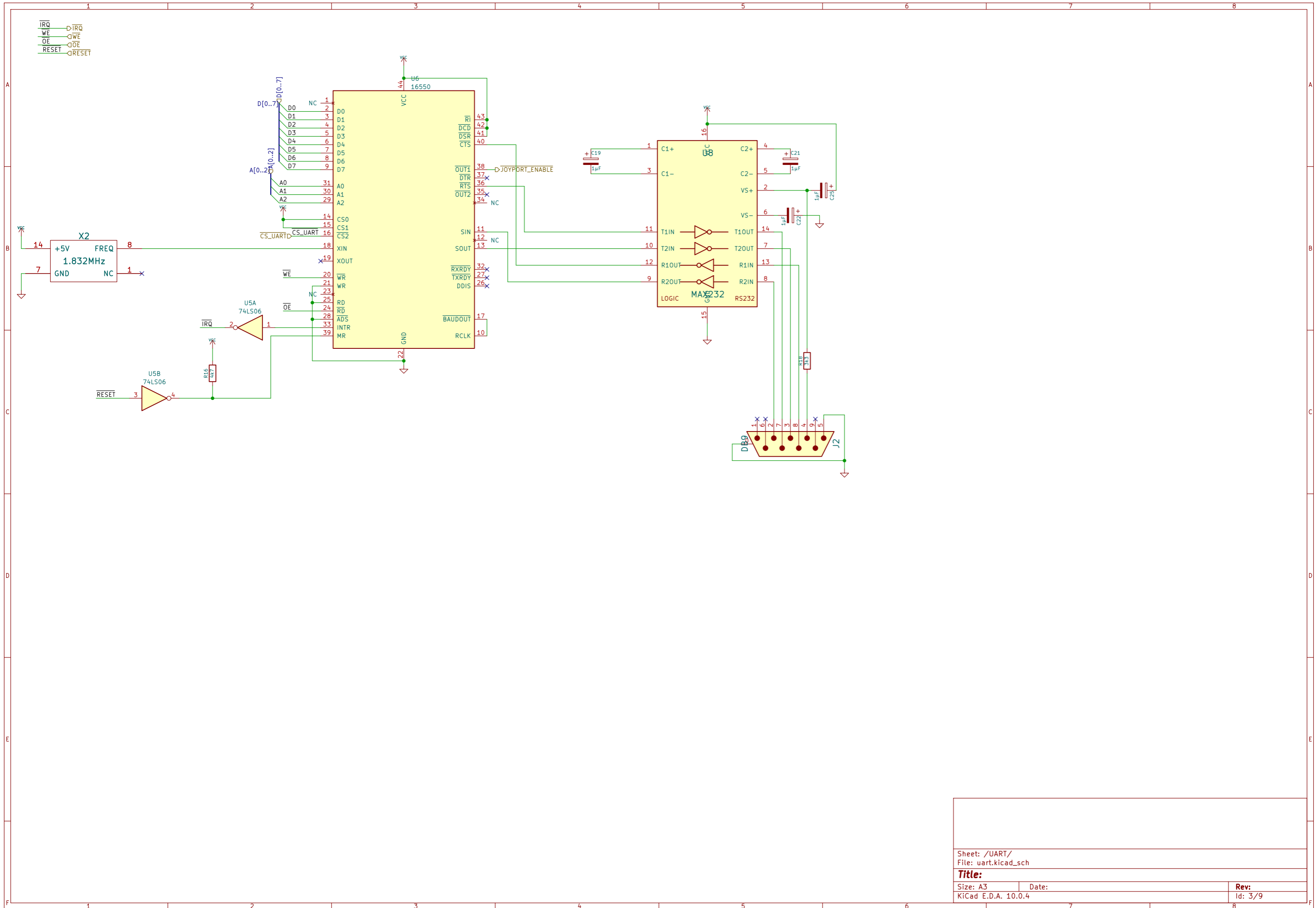

Sheet: /UART/		
File: uart.kicad_sch		
Title:		
Size: A3	Date:	Rev:
KiCad E.D.A. 10.0.4		Id: 3/9

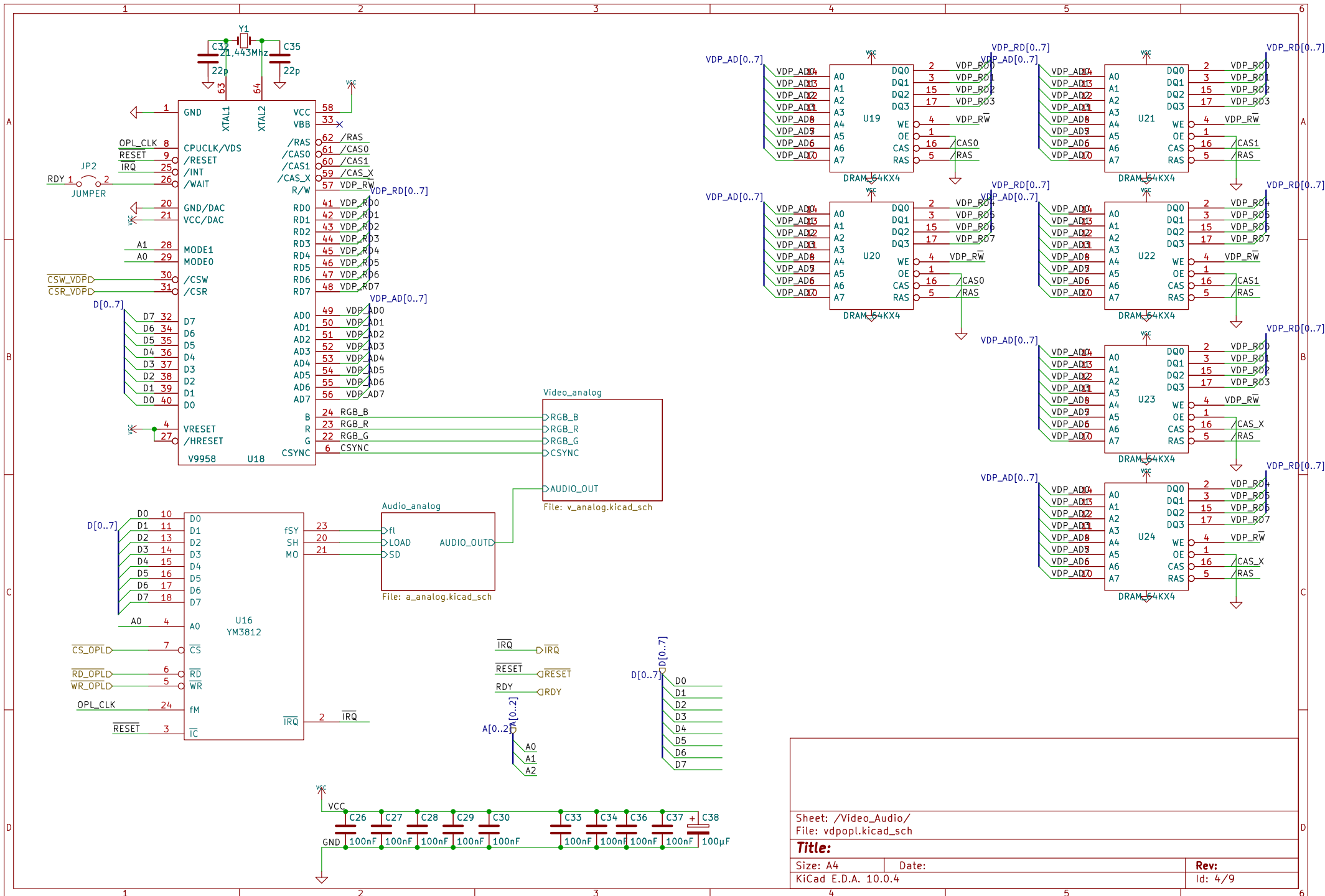

Sheet: /Video_Audio/ File: vdpopl.kicad_sch	
Title:	
Size: A4	Date:
KiCad E.D.A. 10.0.4	Rev: Id: 4/9

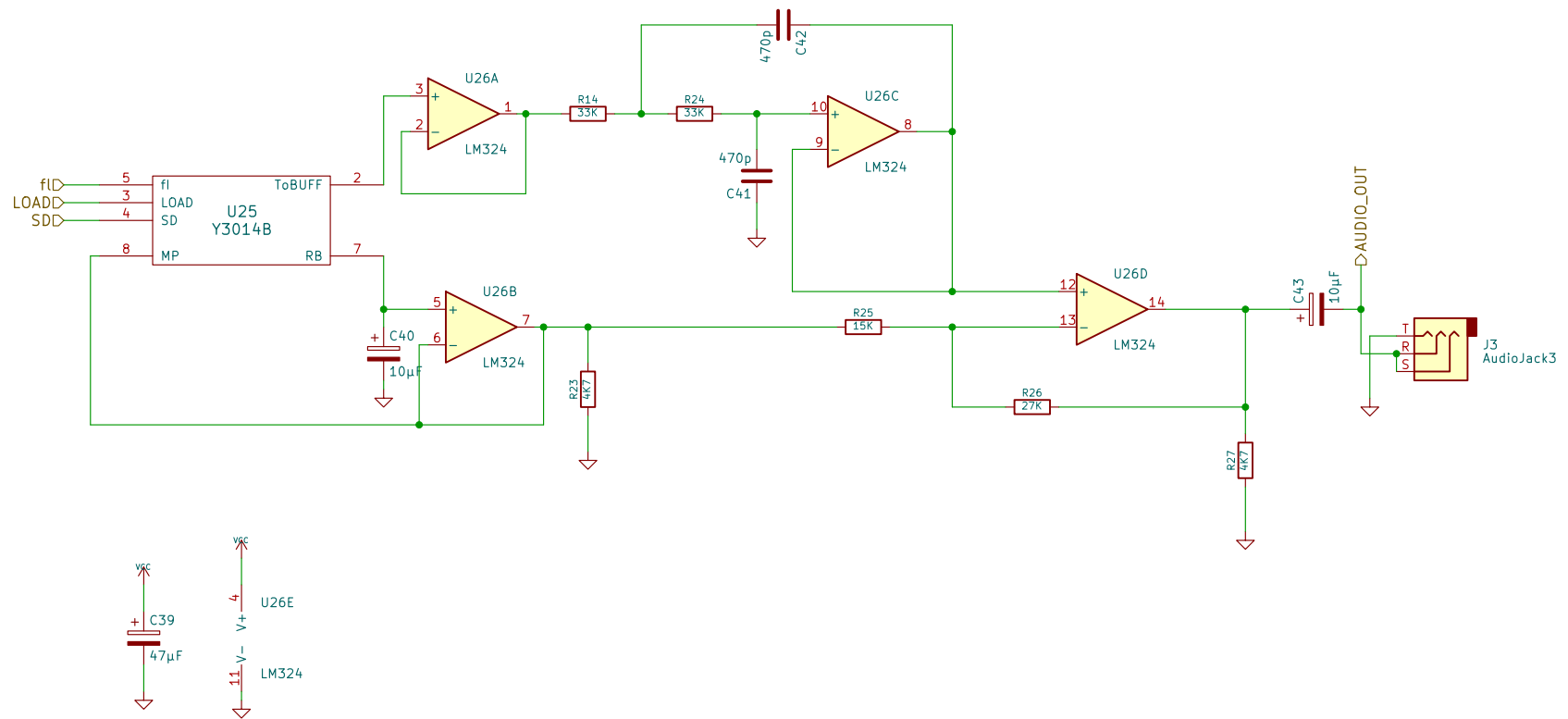

Sheet: /Video_Audio/Audio_analog/
 File: a_analog.kicad_sch

Title:

Size: A4
 KiCad E.D.A. 10.0.4

Date:

Rev:
 Id: 5/9

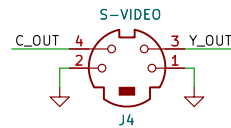
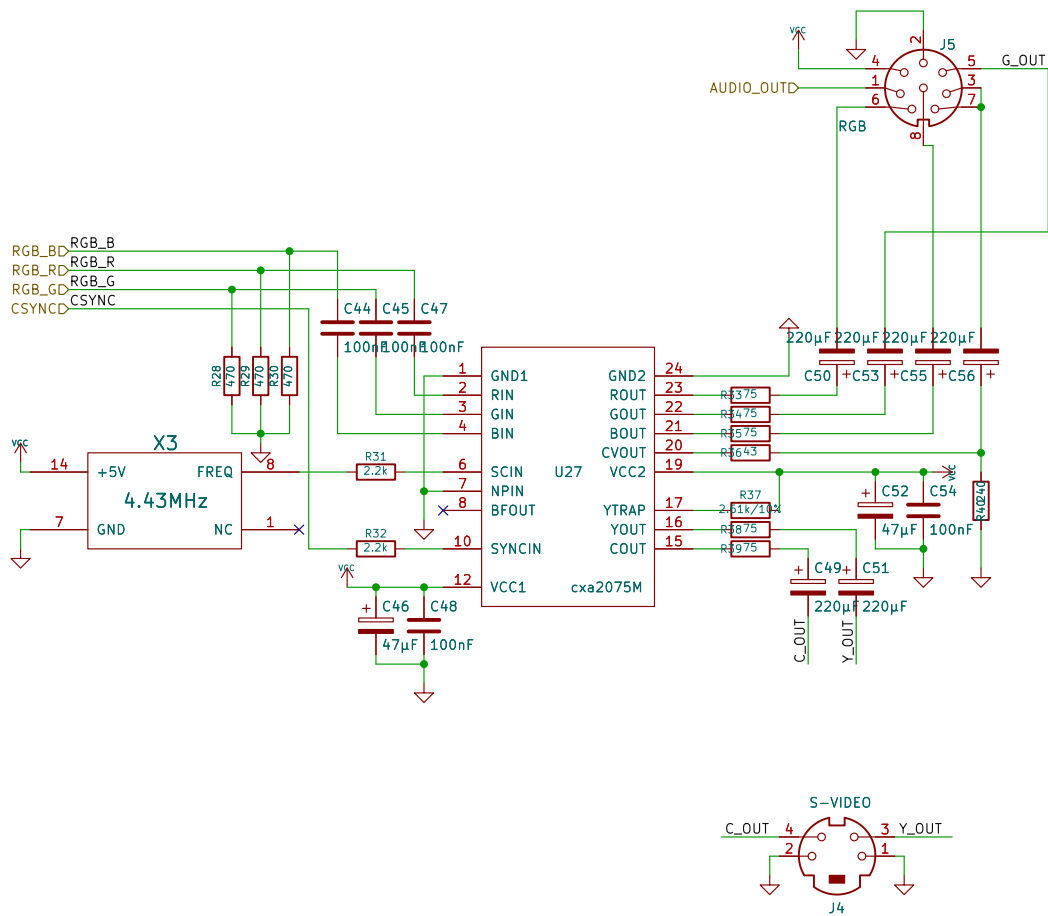

Sheet: /Video_Audio/Video_analog/
 File: v_analog.kicad_sch

Title:

Size: A4
 KiCad E.D.A. 10.0.4

Date:

Rev:

Id: 6/9

NMI —> NMI
 IRQ —> IRQ
 RESET —> RESET

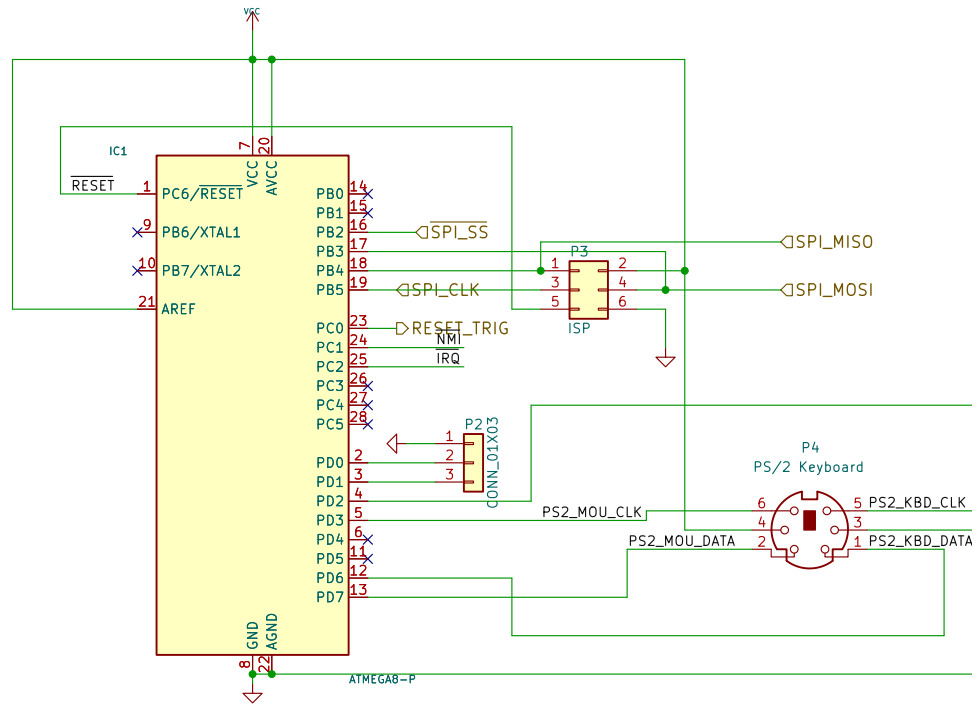

Sheet: /Kbd_controller/
 File: kbd.kicad_sch

Title:

Size: A4
 KiCad E.D.A. 10.0.4

Date:

Rev:
 Id: 7/9

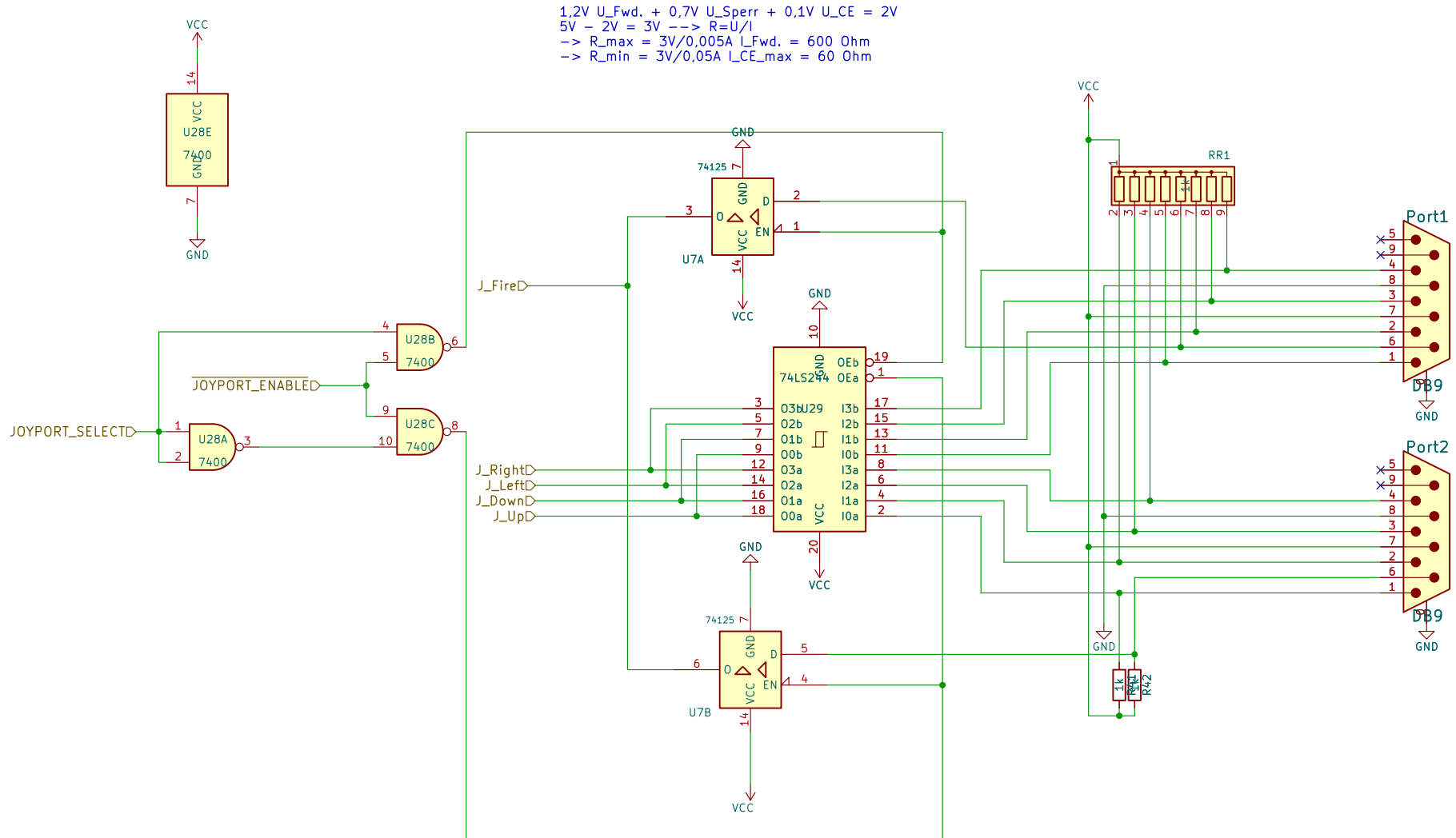

Sheet: /Joysticks/
 File: joysticks.kicad_sch

Title:

Size: A4	Date:	Rev:
KiCad E.D.A. 10.0.4		Id: 8/9

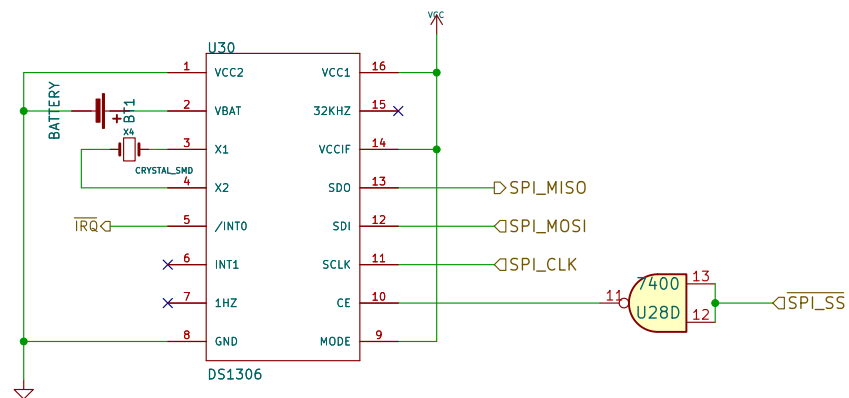

Sheet: /RTC/
 File: rtc.kicad_sch

Title:

Size: A4
 KiCad E.D.A. 10.0.4

Date:

Rev:
 Id: 9/9